



# The FAWSSit™

Fold Away Wheelchair Shower

US Patent Number 7,231,673 B1



## USER CARE GUIDE

Standard S2000, Super Standard SS4040

Bariatric B5000, Tall T4000 Models

## **A Note to You**

**Thank you for buying this product.**

To ensure you enjoy years of trouble-free operation, we developed this User Care Guide for your FAWSSit™ Fold Away Wheelchair Shower. It contains valuable information about how to operate and maintain your portable wheelchair shower properly and safely. Please read it carefully.

# Contents

Shower Safety.....	3
Operating Instructions & Setup.....	4-9
Faucet Aerator Installation and Use.....	10
Electrical Requirements.....	11
Location.....	12
Tools Required.....	12
Accessory Bag.....	12
Return Policy.....	13
Ordering Replacement Parts.....	14
Warranty.....	15
Rinsing, Breakdown and Storage.....	18
Troubleshooting.....	20
Owners Information Sheet.....	21



# Shower Safety

Your FAWSsit™ portable shower safety is important to us. Please read and follow safety instructions below:

- Plug into a grounded 3-prong outlet only. *(Fig. 1)*
- Do not remove ground prong.
- Do not use an adapter.
- Use 3 wire extension cords if necessary.
- Unplug unit before doing any servicing.
- Remember that disposal water is not sanitary. Place the water disposal tube directly into drain, and sanitize disposal area after use. *(Fig. 2)*
- Make sure space is big enough for care attendant to move around the outside of the shower.



**Fig. 1**



**Fig. 2**

## Operating Instructions & Setup

Your FAWSit™ portable wheelchair shower comes packaged fully assembled and ready for use. No tools are required. Your FAWSit™ shower sets up in less than 5 minutes and weighs less than 30 pounds. The best location is in the kitchen of your home or in an area where both hot and cold water resources are available as well as a drain for removing the waste water.

Ensure that you have open space around all sides of the shower. You may slide the back of the shower closer to the water source during setup, but you should allow approximately three (3) feet of space in front and on the sides of the shower. This ensures easy patient access for family members or care attendants.

After unpacking your FAWSit™ shower, stand the unit upright on its support legs. The white rubber protection pads on each of the support legs should be on the floor. (*Fig. 3*)

Pull the right shower wall toward you until it opens to a 90 degree angle (*Fig.4*) Do the same with the left shower wall until it opens to a 90 degree angle as well (*Fig.5*).



**Fig. 3**

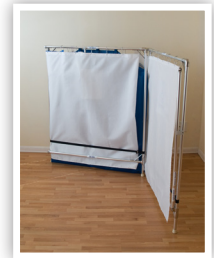

**Fig. 4**

Your portable wheelchair shower should now be set up in a horseshoe configuration with the dark blue shower pan facing you.

Your portable wheelchair shower comes with a dark blue vinyl water collection pan that is attached to the rear wall of your portable shower. A Velcro® strip is wrapped around the upper rear tubing arm for shipping / storage. By pulling up on the Velcro® strip, the blue vinyl water collection pan releases to lay flat on the floor between the rear, left and right shower walls. (Fig.6)

Attach the Velcro strips to the lower support tubing on the sides of the shower to hold the pan edges upright. Leave the front open until after the person in the wheelchair is rolled in.

The back of the shower should face your hot/cold water outlets. A flexible water hose for bathing will be attached to the water faucet later during this setup process (included in your kit). A drain source for bath water removal should also be available, as in your kitchen sink.



**Fig. 5**



**Fig. 6**

## Operating Instructions & Setup con't

Your portable wheelchair shower comes with a support arm that is attached to the right shower wall. Make sure that the support arm on the right side of your portable wheelchair shower is lowered to attach to the left shower wall for additional support after the wheelchair is inside the shower stall. In its lowered position, the support arm sits approximately 6 inches off the floor aligned with the support rails for the left and right side walls as well as the back shower wall. **Special note:** *Do not lower the support arm or attach the front water collection pan to the support arm until the wheelchair and person are completely inside the shower (Fig. 7 & 8).*

Additional Velcro® strips are evenly spaced along the blue vinyl water collection pan. These Velcro® strips wrap around the lower support tubing arms located approximately 6 inches off the floor (Fig. 8). Once these Velcro strips are attached, the water collection pan forms a closed in area for the person and wheelchair. Your water collection pan is designed to be raised slightly in front to allow for bath water to flow to the rear of the collection pan for easier removal by your FAWSsit™ shower's water pump.



Fig. 7



Fig. 8



**Note:** *As stated earlier, the front support arm should not be lowered or attached to the front of the collection pan until the person and the wheelchair are completely inside the portable shower.*

Your portable wheelchair shower comes with a flexible rubber shower hose (*Fig. 9*). This shower hose is approximately 12 feet in length and attaches to your hot / cold water source. The end of your water hose has a cup that attaches by pushing that cup into the faucet head of your water source (*Fig. 10*). Once this is completed your water temperature can be adjusted by the care attendant for the proper temperature for bathing the person in the wheelchair.

The shower head can be attached to the moveable bracket, or it can be hand held. The shower head bracket is a 12 inch aluminum section which snaps to the shower frame on one end, and clamps to the shower head on the other end. (*Fig. 11*)



**Fig. 9**

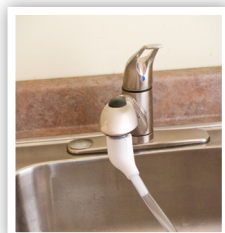

**Fig. 10**

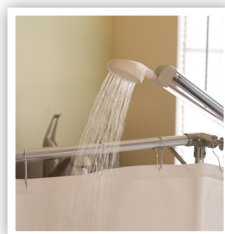

**Fig. 11**

## Operating Instructions & Setup con't

There is an optional quick connect shower hose with a flow control shower head available for the FAWSsit™ showers (Fig. 12). This shower hose has a snap-on attachment for the sink faucet, a 15 foot long hose, and a shower head which has a blue adjustment lever which allows for water to be turned on or off at the shower head as well as at the faucet. There are also special water flow options on this shower head.

Your FAWSsit™ shower's water pump is attached to the rear wall on the right side of your shower approximately 26 inches off the ground. The spun aluminum cap with off/on switch for your water pump is located on the top side of your water pump. **Note:** *By pushing the switch to the up position, the water pump will activate. By pushing down on the switch the water pump will shut off.* (Fig. 13)

The water pump has two drain hoses connected to it. The bottom hose going to the collection pan removes the bath water. The open end of the bottom hose should be placed inside the mesh pocket located at the back of the blue shower pan to hold it in place for suctioning the water from the pan (Fig. 14). *It is very important to keep this bottom suction hose inside the*



Fig. 12



Fig. 13



Fig. 14

*mesh pocket at all times. If the mesh cover collects hair and or other foreign materials, remove it by wiping it up with a paper towel and depositing it in a trash receptacle. DO NOT pull the suction hose out of the mesh cover to remove any foreign material through the pump. This could cause the pump to clog and will void the warranty.* The top hose allows the waste bath water to drain directly into your kitchen drain or bathroom toilet or any drain system convenient for bath water removal. (Fig. 15)



**Fig. 15**

The shower curtains are already pre-hung to three sides of the portable wheelchair shower. An additional section for the front curtain is attached to the left side of your portable shower. By unclipping the inside shower clip from the left rear side of the shower wall, the additional section of the curtain can be attached to the front right side shower wall for complete privacy. (Fig. 16)



**Fig. 16**

Note: Make sure that all sides of the shower curtain are placed *inside* the blue drain pan before running water into the shower stall. **2nd note:** *Once the person has completed their shower, be sure that the support arm is in the raised or up position and that the front vinyl mat is laying flat in front of their wheelchair's wheels before rolling them out.*

# Faucet Aerator Installation And Use

## *One Time Installation:*

1. Remove your faucet's aerator from spout (A).
2. If spout is threaded on the outside, place thinner washer only (B) inside enclosed aerator. If spout is threaded on the inside, place thicker washer only (C) inside enclosed aerator.
3. Twist aerator (D) onto the spout (A).

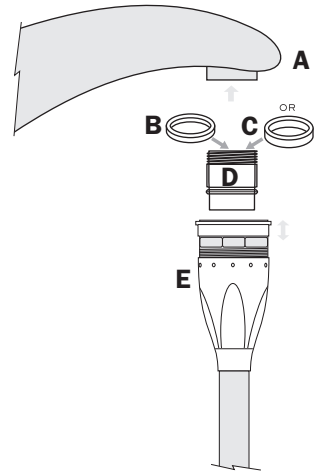

## *Connect Hose:*

4. Snap “quick connector” (E) on aerator by holding down white ring while pushing hose up onto aerator.
5. Turn on water. Press sprayer to start water flow.

## *Disconnect Hose:*

6. Turn off water. Disconnect hose by holding down white ring on “quick connector” and pull down to detach hose from aerator.
7. Hold hose end over sink, then elevate sprayer and press sprayer button to drain remaining water in hose.

Occasionally the aerator (D) becomes separated during shipping. If this happens to you, please call 1-877-329-7748 and we will help you reassemble the aerator. This will not affect the performance of the product.

## Electrical Requirements

Your portable wheelchair shower comes with an 11 foot power cord terminated with an automatic ground fault interrupter (GFI) plug. This power supply cord is attached to the shower's water pump and hangs from a plastic storage strap when not in use to keep it dry and safe from damage.



The pump operates on 115 volts AC, 50/60 cycle and draws 1.50 amps. The GFI must be plugged into a 3 wire, *grounded*, 115 volt outlet. The ground path ***must not*** be defeated by the use of a 2 wire cord, a 3 wire to 2 wire adaptor, or the removal of the ground pin.

If a grounded 3 wire outlet is not available, it is the customer's responsibility to have a 3 wire grounded outlet installed. If in doubt, contact a licensed electrical installer to have the proper receptacle installed. All installations must be in conformance with the National Electrical Code, ANSI/NFPA 70, latest edition, and all local codes and ordinances. Copies of the code may be obtained from the National Fire Protection Association, Batterymarch Park, Quincy, Massachusetts 02269.

## Location

Check the location where your portable wheelchair shower will be installed. Proper installation is your responsibility. Make sure you have everything necessary for correct installation.

The location should provide:

- Grounded electrical outlet within four to six feet of the portable shower unit. Use 3 wire extension cord if necessary.
- Free movement around the portable shower unit, approximately 3 feet around all sides of your wheelchair shower unit and a least 9 feet of space from front to end of your Recliner Shower. (*Fig. 16*)
- Do not install the portable shower unit where the shower curtains will be exposed to heat sources that will raise the panel surface temperature above 120 degrees Fahrenheit (50 degrees Celsius).



**Fig. 16**

## Tools Required

- None

## Accessory Bag

- The blue mesh utility bag can be used to hold other personal hygiene products, such as shampoo or soap. (*Fig. 17*)



**Fig. 17**

## Return Policy

**The FAWSSit™ shower may be returned if the following conditions exist:**

1. If the box has NOT been opened, and it is returned undamaged within 30 days of ordering, then shipping charges only will be charged.
2. If the box has been opened and the shower taken out of the box, but NO WATER has been run through, there will be a 10% re-stocking charge in addition to the conditions of point number 1.
3. If the unit has been used, or if water has been run through the unit, the product will be possible to return only with special permission and pricing set by the manufacturer.

# Ordering Replacement Parts

You may order the following replacement parts for your FAWSsit™ portable shower from your local authorized dealer or by calling Care Giver Support Products, LLC at 1-877-329-7748 or (510) 483-2949.

- Shower curtains
- Shower hooks
- Accessory bag
- Drain pan
- Hoses
- Pump





# Warranty

## 1. What is the Coverage Period

- a. 10 years on the frame
- b. One year on all other components
- c. Extended warranties may be purchased for \$100 for an additional year, but must be purchased at the original purchase time
- d. Warranties apply from the date of the original invoice, whether or not repairs or replacements are provided during the warranty period.
- e. No representative or person other than Care Giver Support Products, LLC is authorized to assume for us any other warranty in connection with the sale of this product.



## 2. What is covered under the Limited Warranty during the warranty term

- a. All parts defective in material or workmanship. If, during the warranty period, the product appears as though it may be defective, call our Toll Free number (1-877-329-7748). If the product is then alleged to be defective, you will be advised to send it to our Service Center. You will be given shipping instructions when you call the number listed above. Product under warranty, which upon receipt by Care Giver Support Products, LLC is determined to be defective in materials and/

## Warranty con't

or workmanship will be repaired or replaced at Care Giver Support Products option at no cost to you and will be returned. Defective parts will be repaired or replaced with new or refurbished parts at Care Giver Support Products option. Be sure to include a description of the problem and a dated proof-of-purchase receipt with any product returned for warranty repair.

- b. The limited warranty does NOT cover the following:
  - i. *A defect that has resulted from improper or unreasonable use or maintenance, accident, excess moisture to any component, improper storage, lightning, power surges, or unauthorized tampering, alteration, or modification.*
  - ii. *Any damage caused when repairs have been attempted or made by others.*
  - iii. *Any labor charges for dismantling or re-installing of a repaired or replaced unit.*
  - iv. *Any product which no longer has a label bearing the serial number, or which has a label which has been defaced.*
- c. This warranty is non-transferrable and applies only to the original client for whom the product was purchased from an Authorized Dealer or from Care Giver Support Products, LLC.

### 3. Who pays shipping charges

- a. For warranty repairs, you pay to ship the product to Care Giver Support Products, LLC. Care Giver Support Products pays to ship the product or its replacement back to you via ground shipping. Expedited shipping is the responsibility of the client.
- b. For out-of-warranty repairs, you pay to ship the product to Care Giver Support Products, LLC. The cost of ground shipping to the owner is included in the cost of the repairs or replacement.

## Rinsing, Breakdown and Storage of your FAWSit™ Shower

Once the person has completed his/her shower it is recommended that the care attendant spray a few gallons of fresh water over the inside shower curtains and the water collection pan. This will remove any left over bath soap and water spots remaining in the shower. Be sure to run the water pump to rinse out the extra water from the collection pan and water pump.

A small amount of water may remain in the bottom of the blue collection pan. This residual water can be removed with a soft cloth towel or a sponge.

Once the FAWSit™ shower is rinsed and dried completely, you're ready to reverse the setup process: *(Fig. 7, 6, 5, 4, 3)*

- Unplug the GFI electric power cord from your wall outlet.
- Coil up the power cord and hold it with the clear plastic strap.
- Remove the water spray hose coming from the faucet water source.
- Coil up the hose and hold it with one of the clear plastic straps.
- Release the Velcro® strips from the front of the blue water collection pan as well as the Velcro® strips from the lower left and right shower wall support arms that the blue vinyl collection pan is attached to.
- Lift up on the lower front support arm between the left and right shower walls and snap it into its plastic holder on the right shower wall.
- Pick up the blue water collection pan with the center front Velcro® strip and fold it in half. Lift it completely off the floor and take it back toward

the rear top support arm folding half of it over the top rear support arm.  
Note: Your water collection pan should remain snapped in place to the lower rear support arm of your shower.)

You now have the blue water collection pan hanging from the rear shower wall between the left and right shower walls and curtains.

You can now gently pick up the front end of the left shower wall and close it inward toward the rear shower wall. Do the same with the right shower wall, gently picking it up and closing it inward toward the rear shower wall. The right shower wall will click into a small plastic device mounted on the top back side of the closed left wall panel.

You now have a shower unit that is 8 inches in thickness, including its water pump, which is ready for storage. **And you did it with no tools!** It should store easily under a standard bed, in a closet, on a wall hook, or any place of your choosing.

If the shower is to be stored in sub-freezing temperatures, ensure that all water has been removed prior to storage.



Fig. 7



Fig. 6

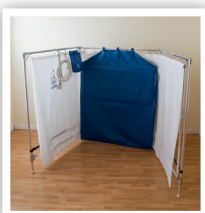

Fig. 5

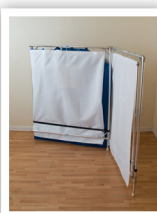

Fig. 4

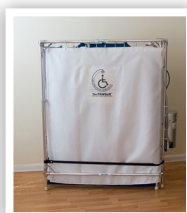

Fig. 3

# Troubleshooting

**If the shower unit will not operate:** Check to see if power supply cord is unplugged. If so, firmly plug the cord into a live outlet with proper voltage.

Check to make sure the GFI Plug is reset. If not, push the reset button to reset. Power should be restored.

**If the power has failed:** Wait until local power is restored. GFI Plug may need to be reset on power cord.

**If the shower has no power:** Check the circuit breaker at the electrical circuit box. If circuit breaker has tripped, reset circuit breaker at the electrical box.

**If the water pump does not pump water:** Check to make sure pump is turned on. If so, unplug power cord from power source and reinsert. Check to make sure that the GFI plug is reset. Reset by pushing in on the reset button.

**If water drips onto floor area from the portable shower collection pan:** Check the vinyl collection pan for holes or breaks in the seams of the collection pan. Make sure the front collection pan is Velcro'd properly to front support arm.

For service support call Customer Service  
[1-877-329-7748](tel:1-877-329-7748).



## Owners Information Sheet

To activate warranty, please return to:

Care Giver Support Products, LLC • 415 Woodland Park • San Leandro, CA 94577

**Dealer:** \_\_\_\_\_

Company: \_\_\_\_\_

Address: \_\_\_\_\_

City/State/Zip Code: \_\_\_\_\_

Phone: \_\_\_\_\_ Fax: \_\_\_\_\_

### Client Information

Name: \_\_\_\_\_

Address 1: \_\_\_\_\_

Address 2: \_\_\_\_\_

City/State/Zip: \_\_\_\_\_

Phone: ( \_\_\_\_\_ ) \_\_\_\_\_

Email: \_\_\_\_\_

Date of Delivery: \_\_\_\_\_

### Unit Information

#### FAWSsit™™

Shower Model: \_\_\_\_\_

Water Pump #: \_\_\_\_\_

---

Client Signature

# Product Specifications

## S2000 STANDARD



- Inside dimensions: 34" wide X 34" deep X 48" tall
- Outside dimensions: 36" wide X 36" deep X 48" tall
- Weight: 28 pounds
- Dimensions when folded: 36" wide X 8" deep X 48" tall

## SS4040 SUPER STANDARD



- Inside dimensions: 40" wide X 40" deep X 48" tall
- Outside dimensions: 42" wide X 42" deep X 48" tall
- Weight: 31 pounds
- Dimensions when folded: 42" wide X 8" deep X 48" tall

## B5000 BARIATRIC

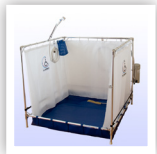

- Inside dimensions: 44" wide X 44" deep X 44" tall
- Outside dimensions: 46" wide X 46" deep X 44" tall
- Weight: 36 pounds
- Dimensions when folded: 46" wide X 8" deep X 44" tall

## T4000 TALL



- Inside dimensions: 34" wide X 34" deep X 72" tall
- Outside dimensions: 36" wide X 36" deep X 72" tall
- Weight: 38 pounds
- Dimensions when folded: 36" wide X 8" deep X 72" tall





All FAWSit™ showers have an attached waste water pump which is designed to run wet or dry and can remove approximately 3 gallons of water per minute while running. This pump has been tested by Underwriter Laboratories for safety. All supporting documentation and additional specifications are available as needed upon request from Care Giver Support Products, LLC.



**Care Giver Support Products, LLC**

1933 Davis Street, Suite 299

San Leandro, CA 94755

E-mail: [info@cgsp.net](mailto:info@cgsp.net)

**1-877-FAWSsit™ (329-7748)**

**Web-site: [www.FAWSsit.com](http://www.FAWSsit.com)**