

# SRE-2010 ELITE STRAIGHT INDOOR STAIRLIFT TECHNICAL APPLICATION DRAWING

## TECHNICAL DATA/SPECIFICATION

**MODEL:** SRE-2010 ELITE  
**RATED LOAD:** 400 LBS., ONE PASSENGER  
**POWER SOURCE:** 24 VOLT DC COMPRISED OF (2) 7 AMP/HR 12 VOLT SEALED BATTERIES  
 100-240 VOLT AC 1.5 AMP, 24 VOLT DC 2 AMP CONTINUOUS MONITORING CHARGER.  
**DRIVE:** 24 VOLT DC DIRECT DRIVE GEAR-MOTOR, 2 POLE RATED .68 HP, 58:1 RIGHT ANGLE SELF LOCKING GEARBOX, 41.5 RPM NO LOAD RPM OUTPUT SPEED.  
**SUSPENSION:** RACK & PINION - INTEGRATED 8DP GEAR RACK ON RAIL WITH A SPUR GEAR ON THE OUTPUT SHAFT OF THE GEAR BOX.  
**BRAKING:** DYNAMIC MOTOR BRAKING THROUGH THE MOTOR CONTROLLER, SELF LOCKING WORM GEAR, AND ELECTRO-MECHANICAL MOTOR BRAKE.  
**CONTROLS:** CONTINUOUS PRESSURE ARMREST SWITCH LOCATED ON THE ARM REST AND WALL MOUNTED CALL/SEND CONTROLS LOCATED AT BOTH THE TOP AND BOTTOM LANDINGS.  
**ANGLES:** 0 TO 45° (SPECIALS UP TO 50°) RIGHT OR LEFT HAND ORIENTATIONS.  
**KEYED CONTROL ON CARRIAGE**  
**FINAL LIMIT SWITCH STANDARD**  
**OPTIONS:**  
 1) KEYED CALL/SEND CONTROLS,  
 2) COMMERCIAL PACKAGE W/OVERSPEED SAFETY BRAKE.

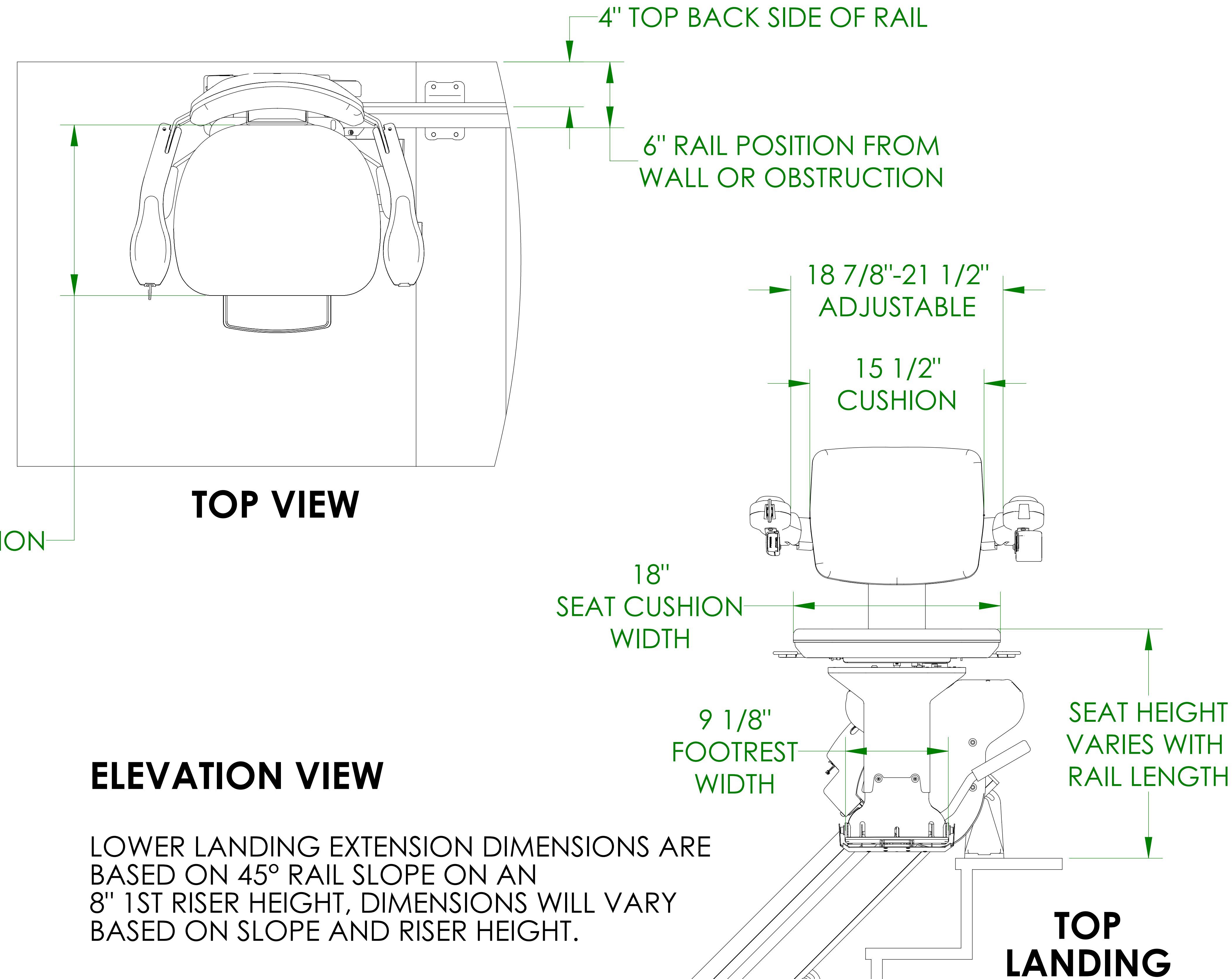

## ELEVATION VIEW

LOWER LANDING EXTENSION DIMENSIONS ARE BASED ON 45° RAIL SLOPE ON AN 8" 1ST RISER HEIGHT, DIMENSIONS WILL VARY BASED ON SLOPE AND RISER HEIGHT.

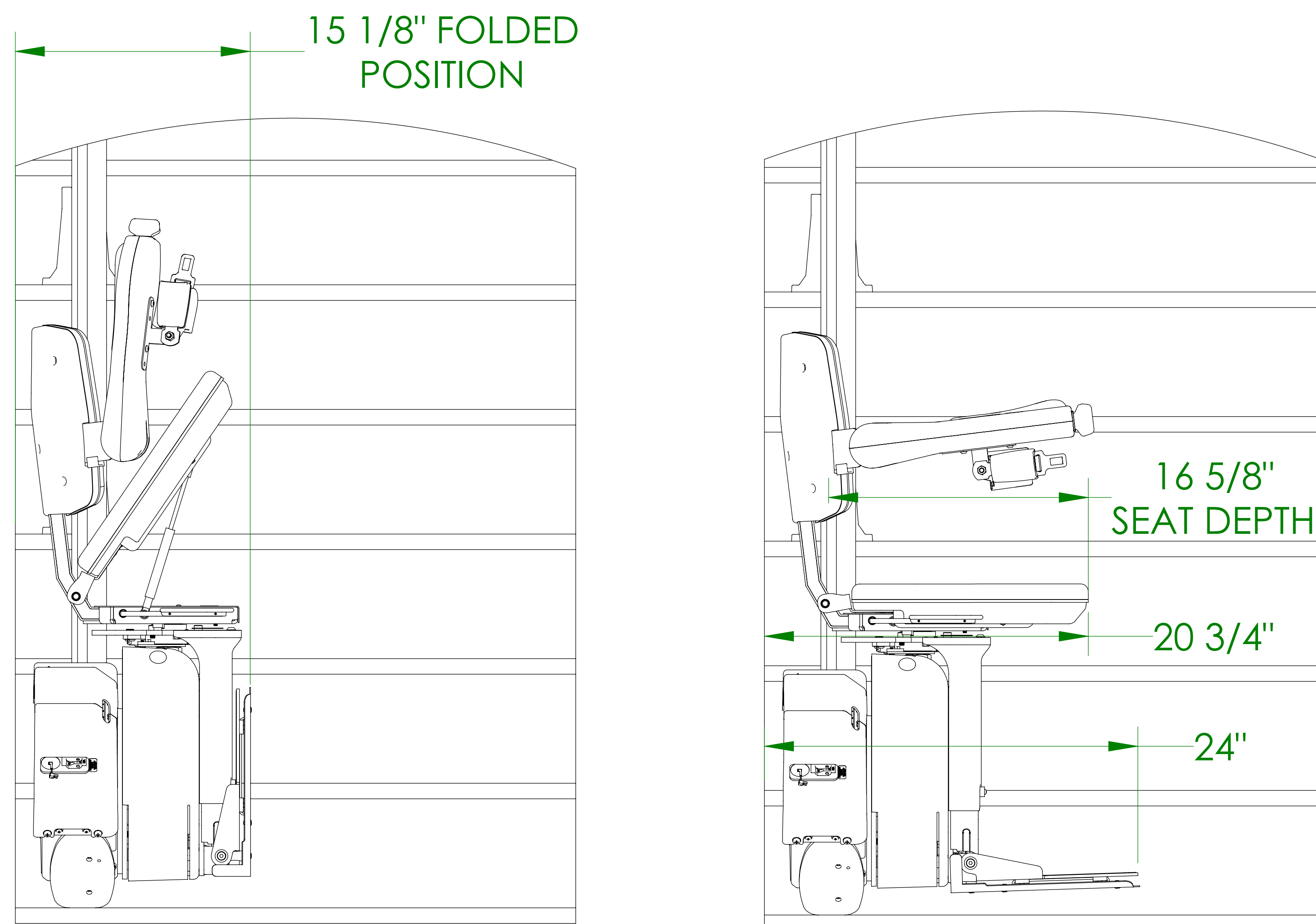

## SIDE VIEWS

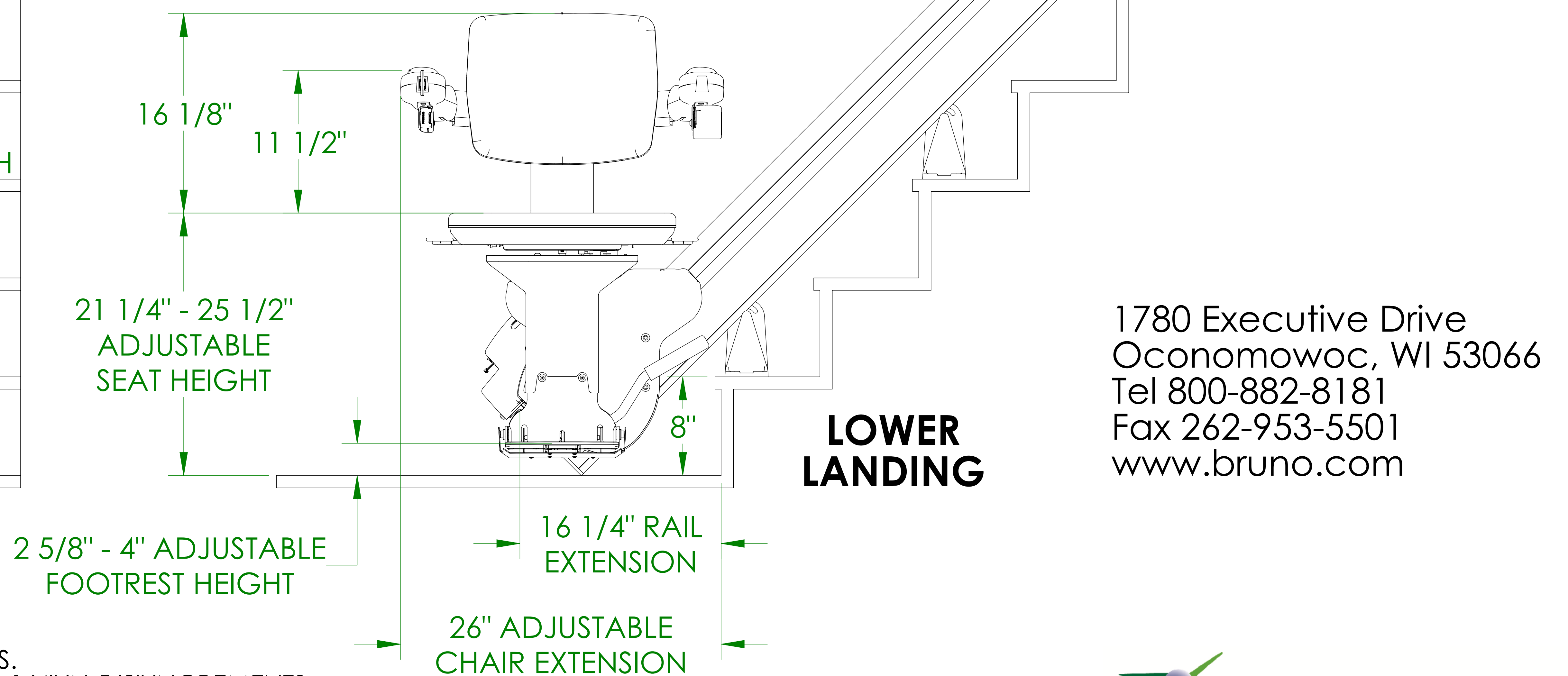

1780 Executive Drive  
 Oconomowoc, WI 53066  
 Tel 800-882-8181  
 Fax 262-953-5501  
 www.bruno.com

**NOTES:**  
 1. ALL SEATS ADJUST UP 3" IN 1" INCREMENTS.  
 2. STANDARD FOOTREST ADJUSTMENTS UP 1 1/4" IN 5/8" INCREMENTS.

**ILS-01343**  
**SHEET 1 OF 3**  
**REV. 8 (7792)(04/21/23)(RJH)**



# SRE-2010 ELITE STRAIGHT INDOOR STAIRLIFT TECHNICAL APPLICATION DRAWING

## DISTANCE FROM WALL - SEAT SWIVELED

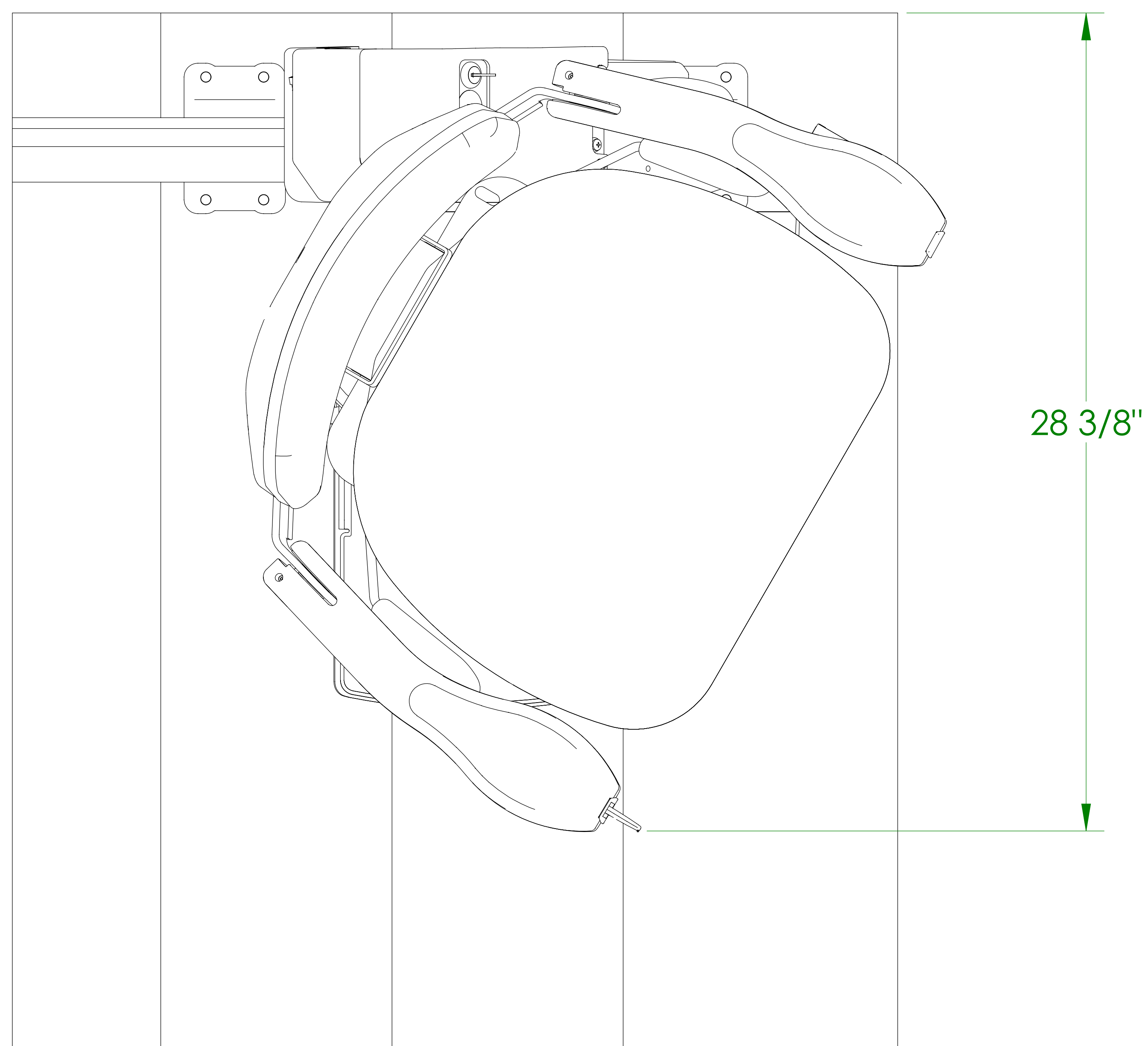

**SEAT SWIVELED 60°**

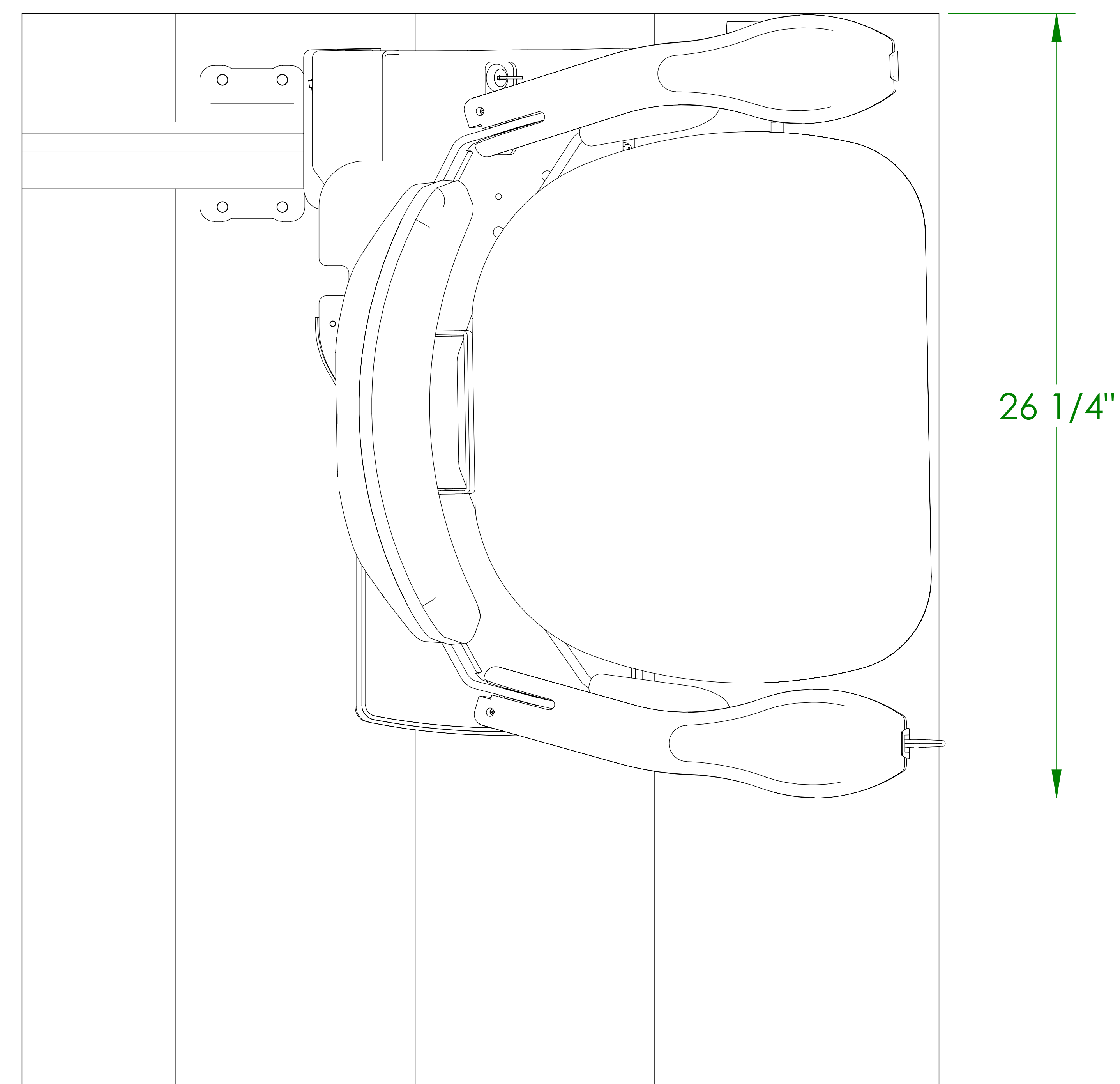

**SEAT SWIVELED 90°**

1780 Executive Drive  
Oconomowoc, WI 53066  
Tel 800-882-8181  
Fax 262-953-5501  
www.bruno.com

**ILS-01343**  
**SHEET 2 OF 3**  
**REV. 8 (7792)(04/21/23)(RJH)**



©Bruno Independent Living Aids, Inc.

# SRE-2010 ELITE STRAIGHT INDOOR STAIRLIFT TECHNICAL APPLICATION DRAWING

## FOLDING RAIL

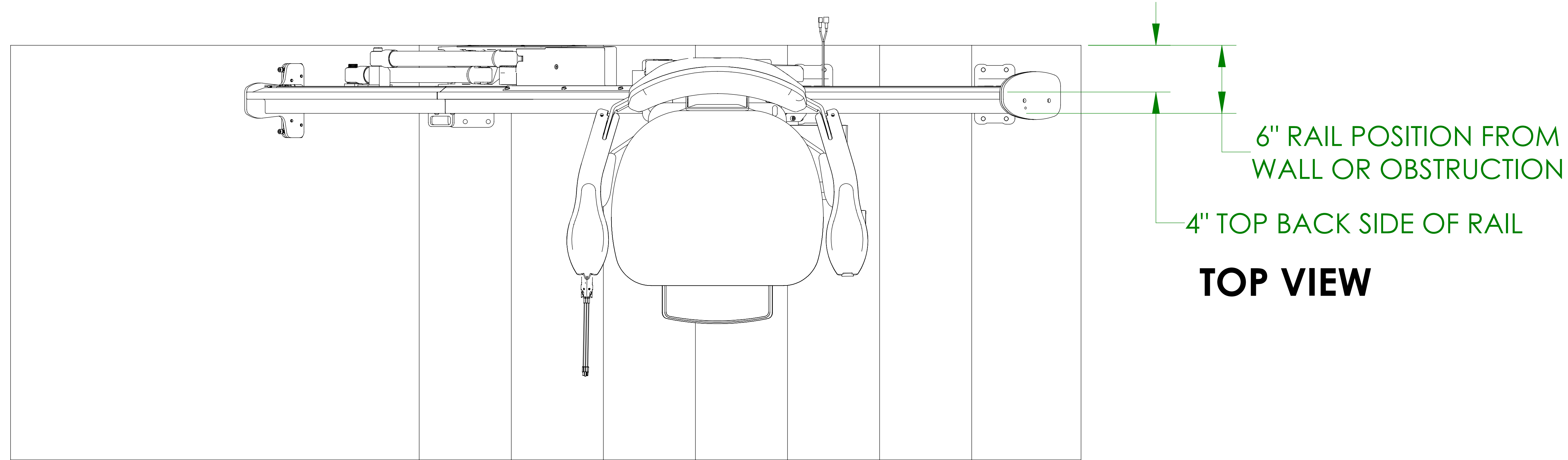

**TOP VIEW**

**AUXILIARY ELEVATION VIEW  
RAIL FOLDED UP POSITION**

**AUXILIARY ELEVATION VIEW  
RAIL FOLDED DOWN POSITION**

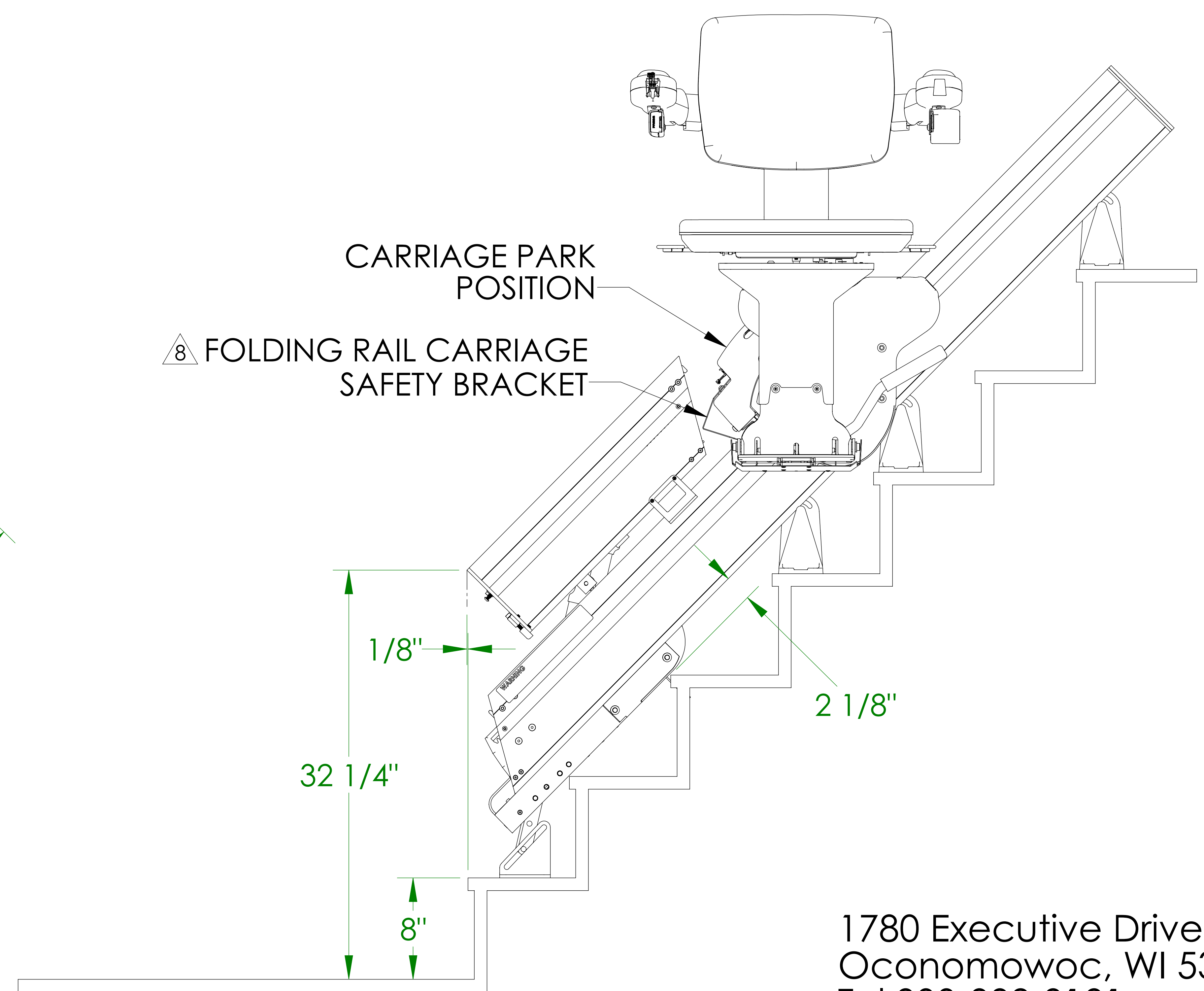
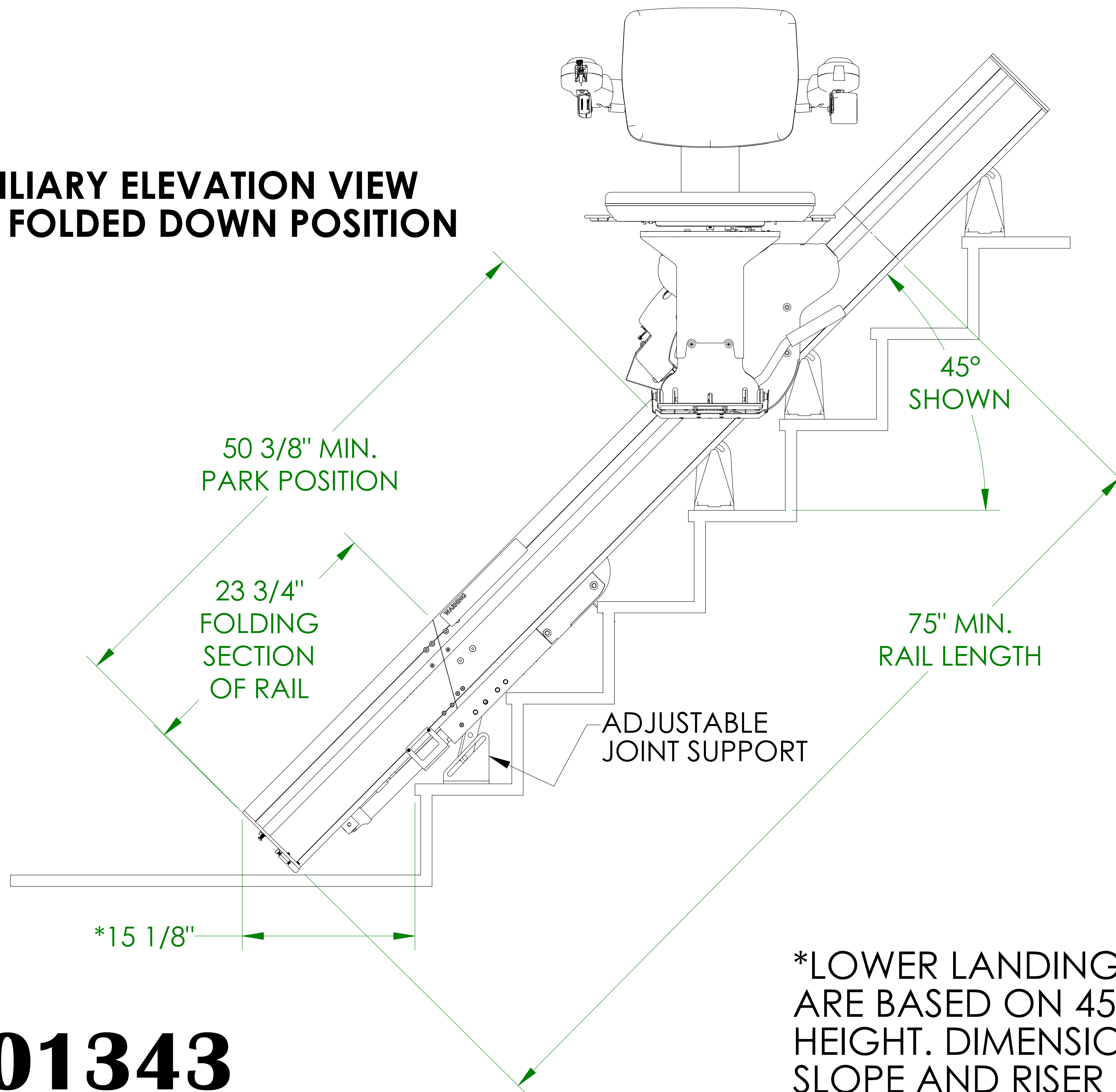

\*LOWER LANDING EXTENSION DIMENSIONS ARE BASED ON 45° RAIL SLOPE AND 8" RISER HEIGHT. DIMENSIONS WILL VARY BASED ON SLOPE AND RISER HEIGHT.

1780 Executive Drive  
Oconomowoc, WI 53066  
Tel 800-882-8181  
Fax 262-953-5501  
www.bruno.com