

# MODEL: 4LBS24038A75FTB.V3\* L/R

\*ALL ACCESSORIES OPTIONAL

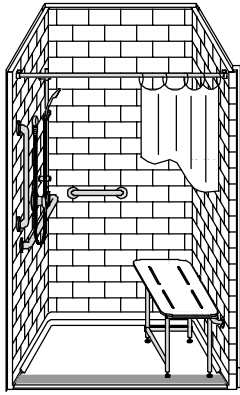

SEE OVER



**PERSPECTIVE VIEW - N.T.S.**  
**MODEL SHOWN HERE AS:**  
 LEFT PLUMBING  
 RIGHT SEAT  
 RIGHT REVEAL

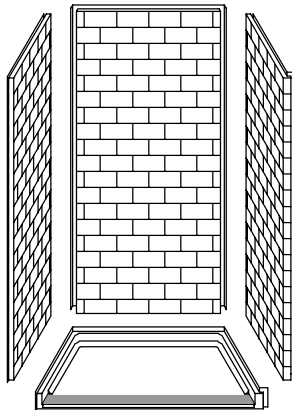

**ASSEMBLY VIEW - N.T.S.**

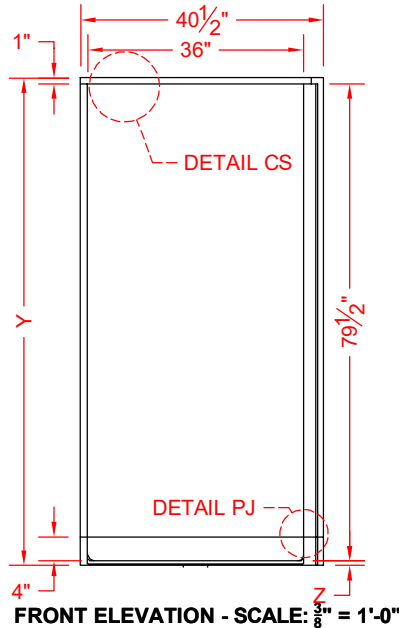
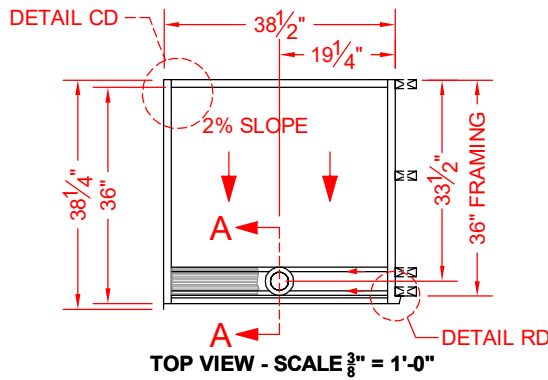

## Features:

- ADA compliant multi-piece transfer shower with trench drain and stainless steel grate
- Molded, four-piece gelcoat/fiberglass shower module
- "Subway Tile", 4" x 8" simulated tile wall finish, white (standard)
- Integral full wood backing for strength and unlimited accessory placement
- Available in various threshold heights
- On all threshold heights 1-1/4" or shorter, no mud set is required and an anchoring adhesive kit is supplied
- On all threshold heights 1-1/2" or taller, no mud set is required

## \*OTHER THRESHOLD HEIGHTS AVAILABLE UPON REQUEST

MODEL #	UNIT THRESHOLD HEIGHT	
	Y	Z*
4LBS24038A75FTB.V3	81-1/4"	3/4" MIN.
4LBS24038A2FTB.V3	82-1/2"	2" MAX.

\* - SEE BACK FOR DETAIL SECTIONS

## PRODUCT SPECIFICATIONS:

- Multi-piece shower module shall be constructed of gelcoat/fiberglass with full integral plywood backing and have a stainless steel trench drain grate.
- Rough-In: Stud opening +1/4" -0" Nominal Dimensions.

C.S.I. FORMAT SPECIFICATION TEXT AVAILABLE

## PRODUCT INFORMATION:

- Accessories: Factory installed, unless prone to damage during installation/shipping. Polished chrome/satin stainless standard, others available.
- Colors: White as standard, others to match any major fixture manufacturer, also available with sprayable solid surface in many colors
- Custom curb heights, other than shown, are available (between min. and max.)

## OPTIONAL ACCESSORIES:

### INSTALLED BY OTHERS:

- Seat, folding
- Grab bar
- Soap dish
- Mixing valve, pressure-balancing, lever handle, pre-plumbed tee to supply elbow
- Curtain rod brackets
- Curtain and rod
- Trench grate and No-caulk brass drain (INCLUDED)

## CODES:

- Designed and manufactured in compliance with the following standards and codes:
- ANSI Z124.2 Standards for Plastic Showers
  - ADA Accessibility Guidelines for Buildings and Facilities
  - ANSI A117.1 A - Accessible and Usable Buildings and Facilities
  - ANSI A117.1 B - Accessible and Usable Buildings and Facilities
  - IPC International Plumbing Code
  - UPC Uniform Plumbing Code

## NOTICE OF LIMITATION:

- Recess as needed to meet code
- Adhere to floor as required
- Reveal not recommended on common wall



*We reserve the right to make revisions without notice in the design of fixtures or in packaging unless this right has specifically been waived at the time the order is accepted.*

**4LBS24038A75FTB.V3 L/R**

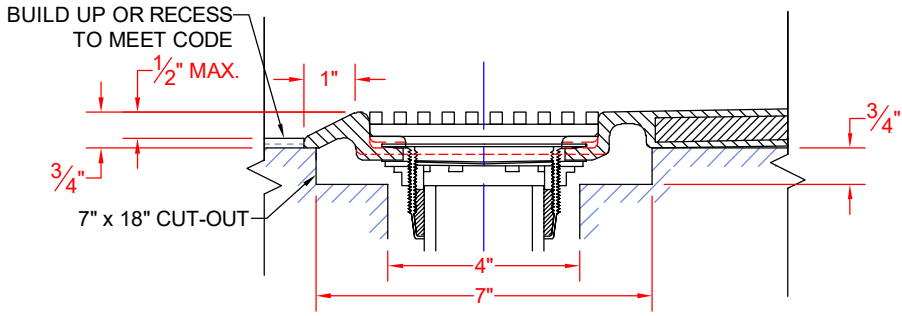

**SECTION A-A - SCALE: 3" = 1'-0"**

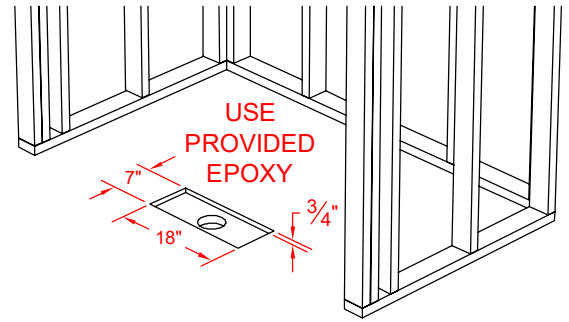

**FOR MODELS ENDING IN A75FT\*.V3, INSTALLATION REQUIRES A 7" x 18" x 3/4" CUT-OUT.**

**4LBS24038A2FTB.V3 L/R**

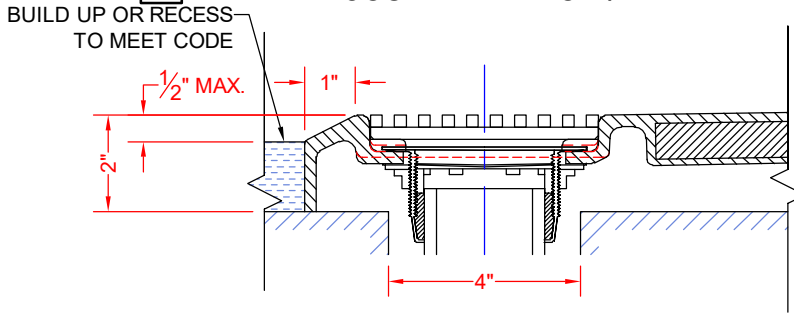

**SECTION A-A - SCALE: 3" = 1'-0"**

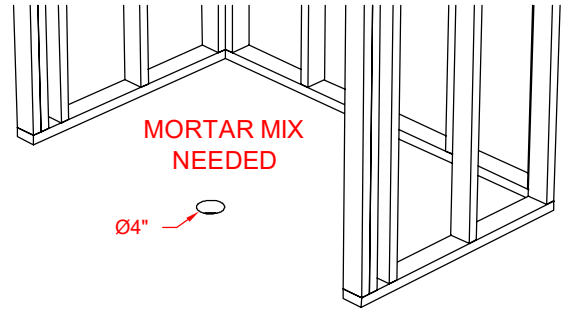

**FOR MODELS ENDING IN A15FT\*.V3, A17FT\*.V3, OR A2FT\*.V3, INSTALLATION REQUIRES A 4" DRAIN HOLE.**

**\*\*OTHER THRESHOLD HEIGHTS AVAILABLE UPON REQUEST\*\***

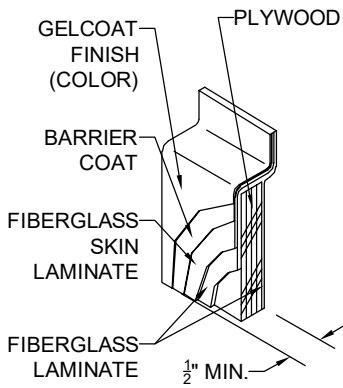

**DETAIL CS - SCALE: N.T.S. CROSS SECTION DETAIL**

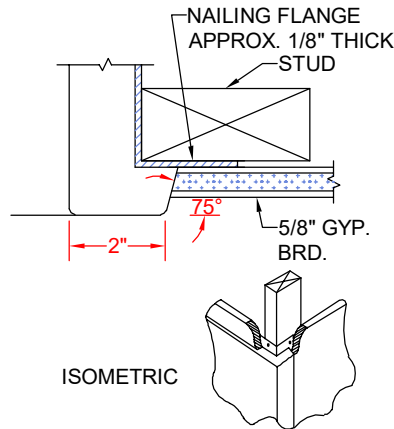

**DETAIL RD - SCALE: N.T.S. REVEAL DETAIL**

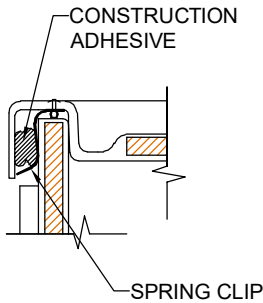

**DETAIL CD - SCALE: 3" = 1'-0" CORNER DETAIL**

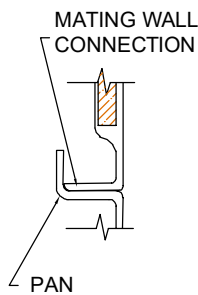

**DETAIL PJ - SCALE: 3" = 1'-0" PAN JOINT DETAIL**